



SWEPT PATH ANALYSIS
 FTA (1998) ARTICULATED VEHICLE

Scale
 0 2 4 8 16m
 Original Size (A1) 1:200 @ A1 1:400 @ A3

SWEPT PATH ANALYSIS
 FTA (1998) HG RIGID VEHICLE

Scale
 0 2 4 8 16m
 Original Size (A1) 1:200 @ A1 1:400 @ A3



AECOM
 5th Floor, 2 City Walk
 Leeds, West Yorkshire, LS11 9AR
 T: +44 (0) 113 391 6800
 F: +44 (0) 113 391 6899
 www.aecom.com

NOTES:

1. SITE PLAN BASED ON OS DATA, TOPOGRAPHICAL SURVEY NEEDED FOR FURTHER DESIGN.
2. UNLESS OTHERWISE STATED, ALL DRAWING UNITS ARE IN METRES.

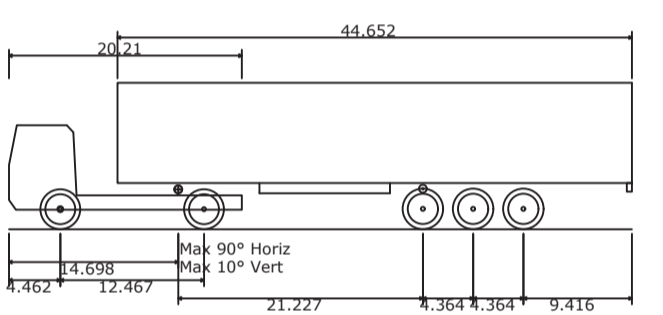

FTA Design Articulated Vehicle (1998)
 Overall Length 54.068m
 Overall Width 8.366m
 Overall Body Height 12.637m
 Min Body Ground Clearance 1.690m
 Max Track Width 8.104m
 Lock to lock time 3.00s
 Kerb to Kerb Turning Radius 21.490m

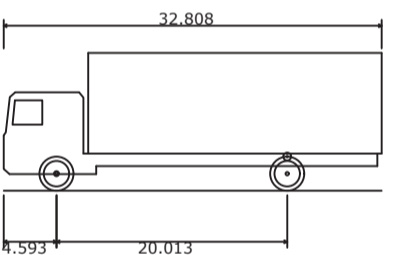

FTA Design HG Rigid Vehicle (1998)
 Overall Length 32.808m
 Overall Width 8.202m
 Overall Body Height 11.957m
 Min Body Ground Clearance 1.444m
 Track Width 8.104m
 Lock to lock time 3.00s
 Kerb to Kerb Turning Radius 36.089m

ISSUE/REVISION

I/R	DATE	BY	DESCRIPTION
A	13.02.2019	TF	FTA HG RIGID SPA ADDED
-	23.01.2019	JC	FIRST ISSUE

KEY PLAN

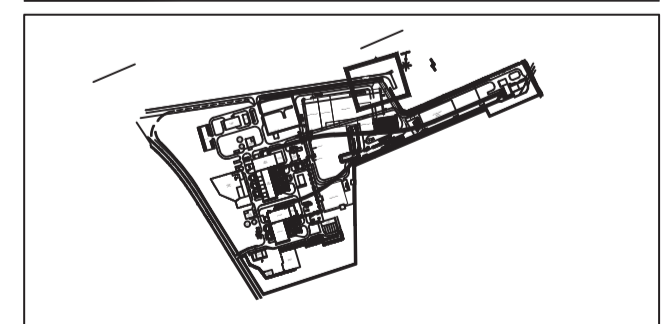

PROJECT NUMBER

60580855

SHEET TITLE

SITE PLAN - SWEEP PATH ANALYSIS

SHEET NUMBER

SK002